

DIST	COUNTY	ROUTE	POST MILES TOTAL PROJECT	SHEET No.	TOTAL SHEETS

Stanley P. Johnson
 REGISTERED CIVIL ENGINEER
 No. CS7793
 Exp. 3-31-16
 CIVIL
 STATE OF CALIFORNIA

October 30, 2015
 PLANS APPROVAL DATE
 THE STATE OF CALIFORNIA OR ITS OFFICERS OR AGENTS SHALL NOT BE RESPONSIBLE FOR THE ACCURACY OR COMPLETENESS OF SCANNED COPIES OF THIS PLAN SHEET.

TO ACCOMPANY PLANS DATED _____

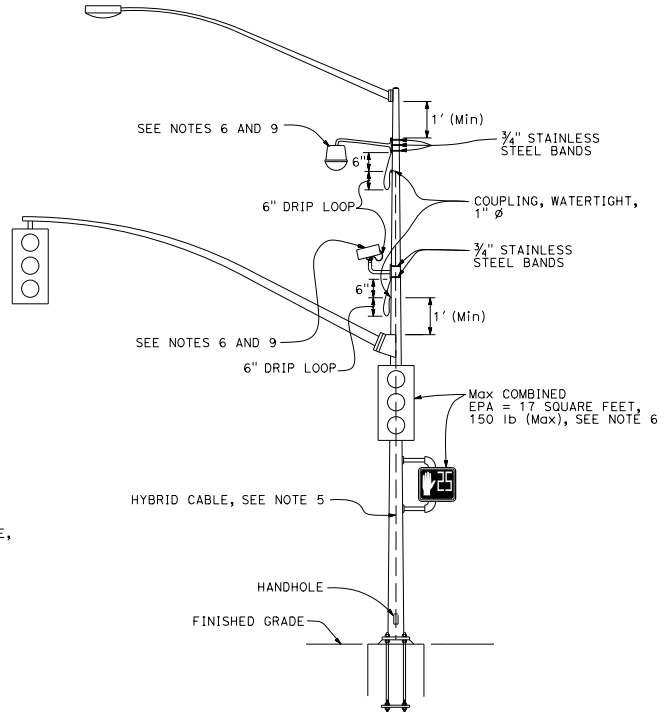
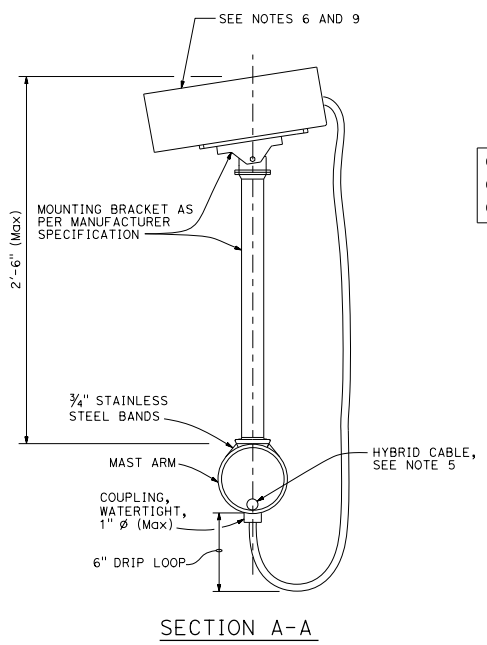

NOTES:

- Exact mounting location of miscellaneous attachment and bracket shall be approved by the Engineer per manufacturer's recommendation.
- Location of cable entrances on signal pole shall be a minimum of 1' from any flange or base plate.
- Hybrid cable entrances on signal pole shall be drilled for weathertight coupling as required.
- Hybrid cable shall have a drip loop at the entrance into signal pole, luminaire mast arm and signal mast arm.
- A single hybrid cable shall run continuous and shall not be twisted from the miscellaneous attachment to the controller cabinet. No splices shall be allowed.
- Use the manufacturer's Effective Projected Area (EPA) for miscellaneous attachment. The maximum EPA for each miscellaneous attachment shall be 1.6 square feet with 10 lb Max.
- Maximum of two miscellaneous attachments per traffic signal standard.
- Maximum of one miscellaneous attachment per mast arm.
- Miscellaneous attachment shall be mounted using clamping devices.

STATE OF CALIFORNIA
DEPARTMENT OF TRANSPORTATION

**ELECTRICAL SYSTEMS
(SIGNAL AND LIGHTING,
MISCELLANEOUS ATTACHMENT)**

NO SCALE

RSP ES-7R DATED OCTOBER 30, 2015 SUPERSEDES RSP ES-7R DATED JULY 19, 2013 AND STANDARD PLAN ES-7R DATED MAY 20, 2011 - PAGE 479 OF THE STANDARD PLANS BOOK DATED 2010.

REVISED STANDARD PLAN RSP ES-7R

2010 REVISED STANDARD PLAN RSP ES-7R