

DIST	COUNTY	ROUTE	POST MILES TOTAL PROJECT	SHEET No.	TOTAL SHEETS

Peter W. Norbo
REGISTERED CIVIL ENGINEER

July 15, 2016
PLANS APPROVAL DATE

THE STATE OF CALIFORNIA OR ITS OFFICERS OR AGENTS SHALL NOT BE RESPONSIBLE FOR THE ACCURACY OR COMPLETENESS OF SCANNED COPIES OF THIS PLAN SHEET.

STATE OF CALIFORNIA
REGISTERED PROFESSIONAL ENGINEER
Peter W. Norbo
No. C57519
Exp. 12-31-17
CIVIL

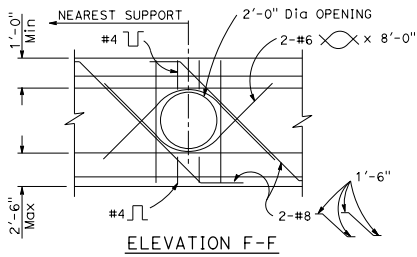

ELEVATION F-F

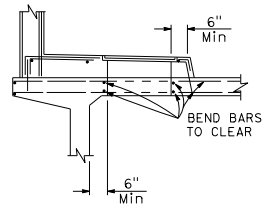

SECTION C-C

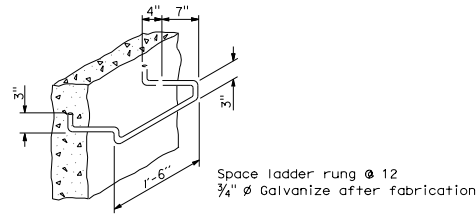

BAR STEP
LADDER RUNG DETAILS
DETAIL U44

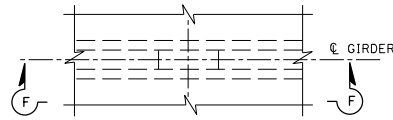

PART PLAN
GIRDER STEM ACCESS OPENING
DETAIL U41

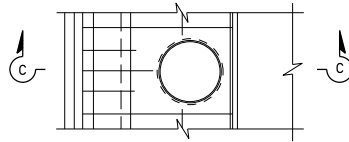

PART PLAN
SIDEWALK ACCESS OPENING
DETAIL U42

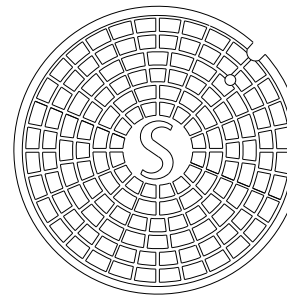

TOP OF MANHOLE COVER

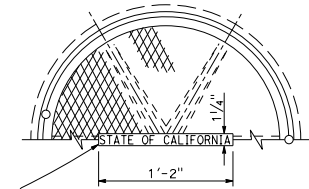

TOP OF MANHOLE FRAME & COVER

NOTES:

- For exact location of openings see other sheets.
- Location and size of manholes may be modified as directed by the Engineer, provided minimum dimensions are maintained.
- All reinforcement detailed to be placed in addition to reinforcement shown on other sheets.

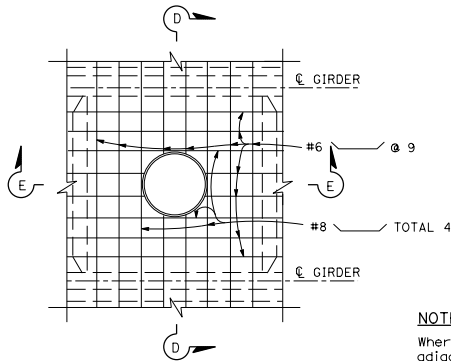

PART PLAN

DECK ACCESS OPENING
DETAIL U43

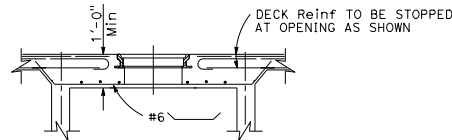

SECTION D-D

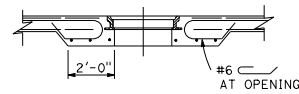

SECTION E-E

NOTE:
Where manhole is located adjacent to a diaphragm or abut, substitute half Section E-E on one side of Section E-E.

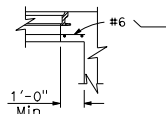

HALF SECTION E-E

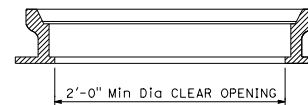

SECTION THROUGH FRAME

NON-ROCKING MANHOLE FRAME & COVER
FOR DECKS
DETAIL U45

NOTES:

- Step inserts may be substituted for the standard step detail. Step inserts shall comply with State Industrial Safety requirements.
- Covers for use on sewer structures shall bear the letter "S"; on storm drain structures the letter "D"; on openings for utilities the letter "U".

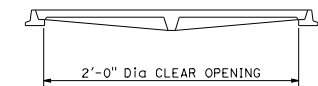

SECTION THROUGH FRAME & COVER

MANHOLE FRAME & COVER
FOR SIDEWALKS
DETAIL U46

NOTES:

- Frame and cover shall be cast iron.
- Cover shall be supplied with bolt down or locking devices.

STATE OF CALIFORNIA
DEPARTMENT OF TRANSPORTATION
UTILITY DETAILS

NO SCALE

RSP B7-11 DATED JULY 15, 2016 SUPERSEDES STANDARD PLAN B7-11
DATED MAY 20, 2011 - PAGE 290 OF THE STANDARD PLANS BOOK DATED 2010.

REVISED STANDARD PLAN RSP B7-11

2010 REVISED STANDARD PLAN RSP B7-11