

DIST	COUNTY	ROUTE	POST MILES TOTAL PROJECT	SHEET NO.	TOTAL SHEETS

Raymond J. Jester
 REGISTERED CIVIL ENGINEER
 January 20, 2017
 PLANS APPROVAL DATE
 No. C37332
 Exp. 6-30-18
 CIVIL
 STATE OF CALIFORNIA

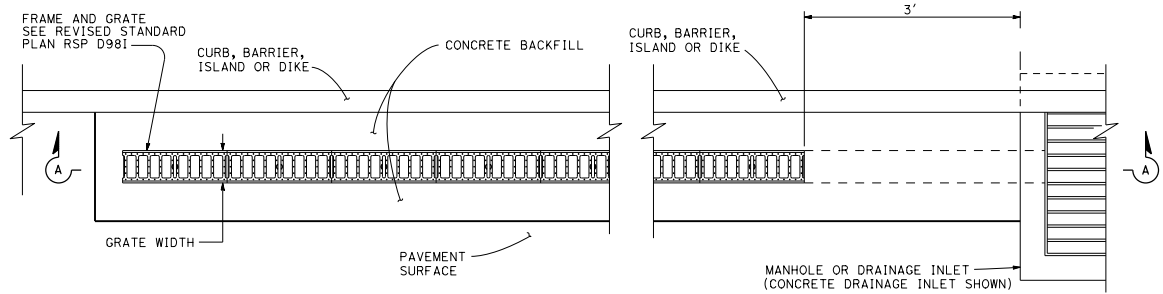

GRADED LINE DRAIN PLAN

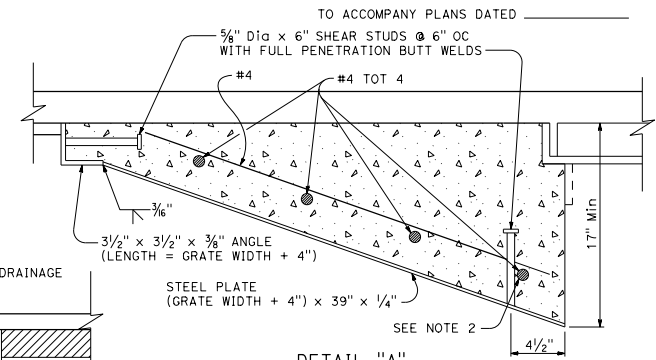

DETAIL "A"

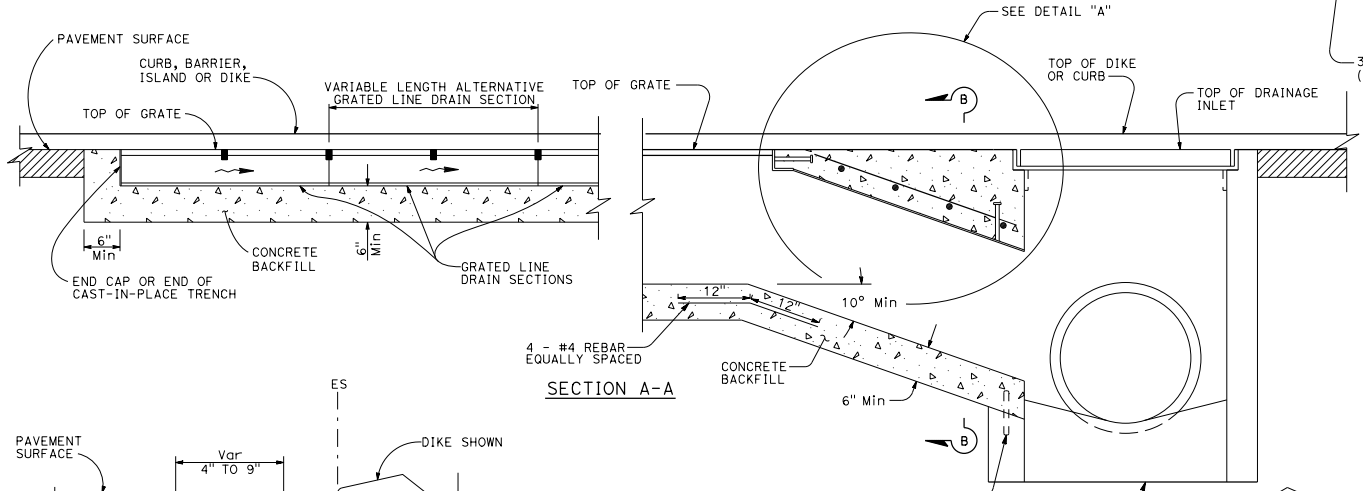

SECTION A-A

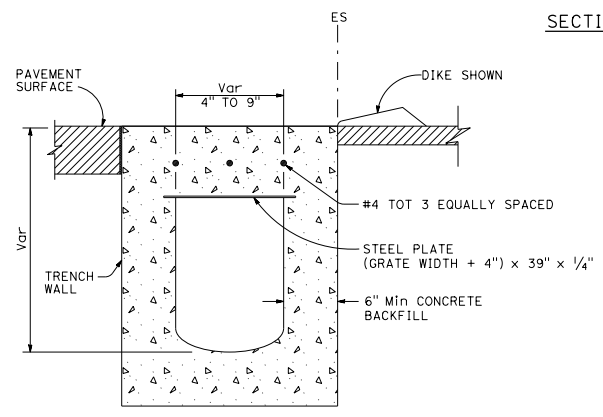

SECTION B-B

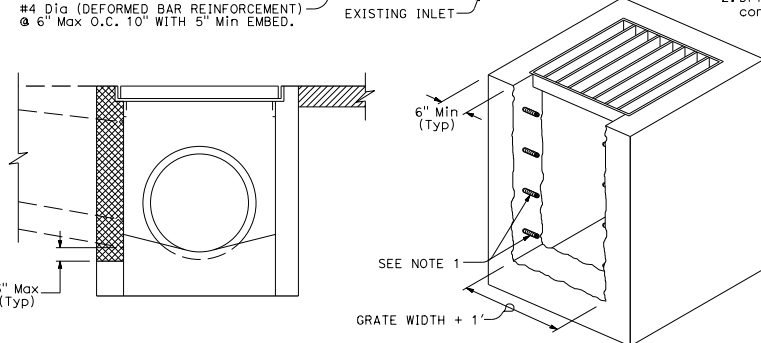

PARTIAL REMOVAL OF EXISTING DROP INLET

LEGEND:

- Pavement
- Limits of Removal

NOTES:

1. Preserve existing rebar during removal of side wall to tie to trench drain reinforcement. Install additional rebar to facilitate connection to drop inlet and replace damaged existing rebar. Doweling perpendicular to side wall in lieu of connecting to existing rebar is not permitted.
2. Drill rebar ends 3" into existing concrete, overlap and connect with double barrel mechanical coupler.

STATE OF CALIFORNIA
 DEPARTMENT OF TRANSPORTATION
**GRADED LINE DRAIN
 DETAILS No. 4 - CONNECTION
 TO EXISTING DRAINAGE
 STRUCTURE**
 NO SCALE

RSP D98J DATED JANUARY 20, 2017 SUPPLEMENTS THE STANDARD PLANS BOOK DATED 2010.

REVISED STANDARD PLAN RSP D98J

2010 REVISED STANDARD PLAN RSP D98J