

DIST	COUNTY	ROUTE	POST MILES TOTAL PROJECT	SHEET NO.	TOTAL SHEETS

Jeffrey G. McRae
REGISTERED ELECTRICAL ENGINEER

January 20, 2012
PLANS APPROVAL DATE

REGISTERED PROFESSIONAL ENGINEER
Jeffrey G. McRae
No. E14512
Exp. 6-30-12
ELECTRICAL
STATE OF CALIFORNIA

THE STATE OF CALIFORNIA OR ITS OFFICERS OR AGENTS SHALL NOT BE RESPONSIBLE FOR THE ACCURACY OR COMPLETENESS OF SCANNED COPIES OF THIS PLAN SHEET.

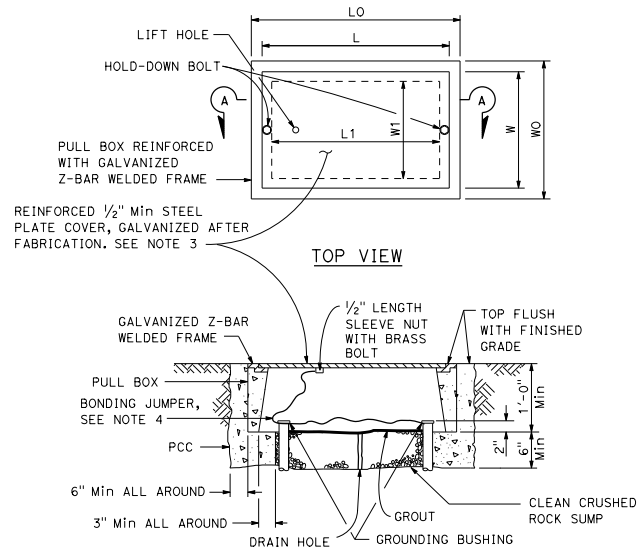

SECTION A-A
**No. 3 1/2(T), No. 5(T) AND
No. 6(T) TRAFFIC PULL BOX**

NOTES ON PULL BOXES:

- Traffic pull box shall be provided with steel cover and special concrete footing. Steel cover shall have embossed non-skid pattern.
- Steel reinforcing shall be as regularly used in the standard products of the respective manufacturer.
- Pull box covers must be marked as follows: "SERVICE" Service circuits between service point and service disconnect; "SPRINKLER-CONTROL" Sprinkler control circuits, 50 V or less; "CALTRANS" On all pull boxes, except pull boxes marked "SPRINKLER-CONTROL"; and "TELEPHONE" Telephone service.
 - No. 3 1/2(T) pull box.
 - "SIGNAL" - Traffic signal circuits with or without street or sign lighting circuits.
 - "ST LIGHTING" - Street or sign lighting circuits where voltage is under 600 V.
 - No. 5(T) or 6(T) pull box.
 - "TRAFFIC SIGNAL" - Traffic signal circuits with or without street or sign lighting circuits.
 - "STREET LIGHTING" - Street or sign lighting circuits where voltage is under 600 V.
 - "STREET LIGHTING-HIGH VOLTAGE" - Street or sign lighting circuits where voltage is above 600 V.
 - "IRRIGATION" - Circuits to irrigation controller 120 V or more.
 - "RAMP METER" - Ramp meter circuits.
 - "COUNT STATION" - Count or speed monitor circuits.
 - "COMMUNICATION" - Communication circuits.
 - "TOS COMMUNICATIONS" - TOS communications line.
 - "TOS POWER" - TOS power.
 - "TDC POWER" - Telephone demarcation cabinet power.
 - "CCTV" - Closed circuit television circuits.
 - "TMS" - Traffic monitoring station circuits.
 - "CMS" - Changeable message sign circuits.
 - "HAR" - Highway advisory radio circuits.
- Bonding jumper for metal covers shall be 3' long, minimum.
- The nominal dimensions of the opening in which the cover sets must be the same as the cover dimensions except the length and width dimensions shall be 1/8" greater.
- Covers and boxes must be interchangeable with California standard male and female gages. When interchanged with a standard male or female gage, the top surfaces must be flush within 1/8".

PULL BOX	BOX						COVER				
	MINIMUM * THICKNESS	MINIMUM DEPTH BOX AND EXTENSION	W0	LO	L1	W1	L **	W **	R	EDGE THICKNESS	EDGE TAPER
No. 3 1/2(T)	1 1/2"	1'-0"	1'-5" ± 1"	1'-8 3/4" ±	1'-2 1/2" ±	10 9/16" ± 1"	1'-8" ±	1'-1 3/4" ±	0"	1/2"	NONE
No. 5(T)	1 3/4"	1'-0"	1'-11 1/2" ± 1"	2'-5 1/2" ±	1'-7" ±	1'-1" ± 1"	2'-3" ±	1'-4" ±	0"	1/2"	NONE
No. 6(T)	2"	1'-0"	2'-6" ± 1"	2'-11 1/2" ±	1'-11 1/2" ±	1'-5" ± 1"	2'-9" ±	1'-8" ±	0"	1/2"	NONE

* EXCLUDING CONDUIT WEB ** TOP DIMENSION

STATE OF CALIFORNIA
DEPARTMENT OF TRANSPORTATION
**ELECTRICAL SYSTEMS
(TRAFFIC RATED PULL BOX)**
NO SCALE

RSP ES-8B DATED JANUARY 20, 2012 SUPPLEMENTS THE
STANDARD PLANS BOOK DATED 2010.

REVISED STANDARD PLAN RSP ES-8B

2010 REVISED STANDARD PLAN RSP ES-8B