

DIST	COUNTY	ROUTE	POST MILES TOTAL PROJECT	SHEET NO.	TOTAL SHEETS

**Randell D. Hiatt**  
REGISTERED CIVIL ENGINEER

PLANS APPROVAL DATE: May 20, 2011

REGISTERED PROFESSIONAL ENGINEER  
No. C60200  
Exp. 6-30-11  
CIVIL  
STATE OF CALIFORNIA

THE STATE OF CALIFORNIA OR ITS OFFICERS OR AGENTS SHALL NOT BE RESPONSIBLE FOR THE ACCURACY OR COMPLETENESS OF SCANNED COPIES OF THIS PLAN SHEET.

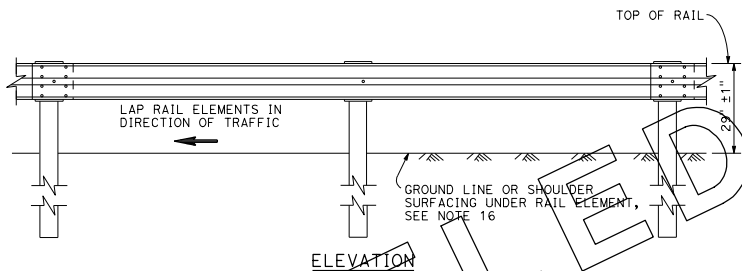
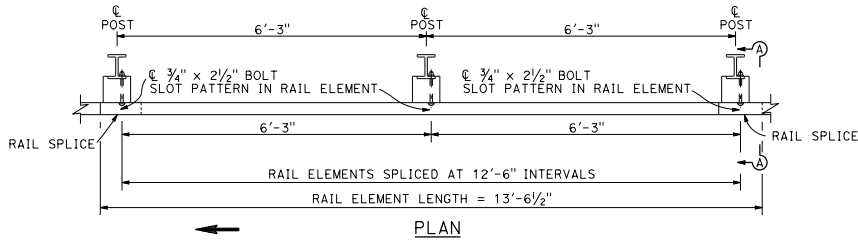

**METAL BEAM GUARD RAILING WITH STEEL POSTS AND NOTCHED WOOD OR NOTCHED RECYCLED PLASTIC BLOCKS**

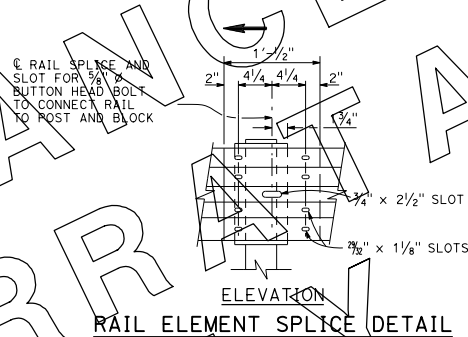

- Connect the overlapped end of the rail elements with  $\frac{1}{2}$ "  $\phi$  x  $1\frac{1}{8}$ " button head oval shoulder splice bolts inserted into the  $\frac{3}{4}$ " x  $2\frac{1}{2}$ " slots and bolted together with  $\frac{3}{8}$ "  $\phi$  recessed hex nuts. Recess of hex nut points toward rail element. A total of 8 bolts and nuts are to be used at each rail splice connection.
- The ends of the rail elements are to be overlapped in the direction of traffic (see details).
- Where end cap is to be attached to the end of a rail element, a total of 4 of the above described splice bolts and nuts are to be used.

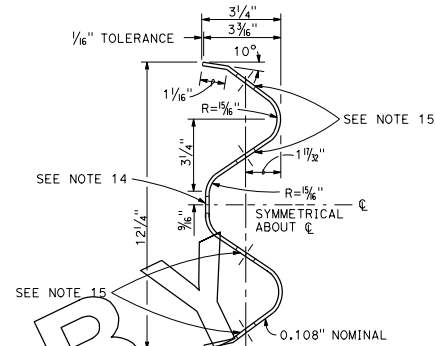

**SECTION THRU RAIL ELEMENT**

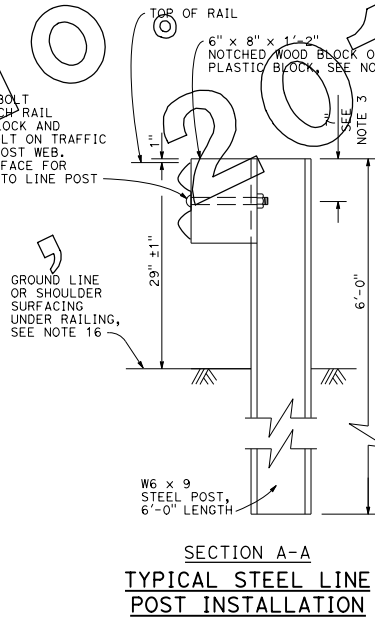

See Note 4

**NOTES:**

- For details of wood post installations, see Standard Plan A77A1.
- For details of standard hardware used to construct guard railing, see Standard Plan A77B1.
- For details of steel posts and notched wood blocks used to construct guard railing, see Standard Plan A77C2.
- For additional installation details, see Standard Plan A77C3.
- Guard railing post spacing to be 6'-3" center to center, except as otherwise noted.
- For guard railing typical layouts, see the A77E, A77F and A77G Series of Standard Plans.
- To connect railing to terminal system end treatment, transition the top of railing height at a ratio of 120:1 to terminal system end treatment height plus one 12'-6" standard railing section at the transitioned height for a horizontal connection to the end treatment.
- For guard railing end anchor details, see Standard Plans A77H1 and A77I2.
- For details of guard railing transition to bridge railing, see Standard Plan A77J4.
- For additional details of guard railing connection to bridge railings, see Standard Plans A77J1, A77J2 and A77K1.
- For dike positioning and guard railing delineation details, see Standard Plan A77C4.
- Direction of adjacent traffic indicated by  $\rightarrow$ .
- Notched face of block faces steel post.
- Slotted hole for bolted connection of rail element to block and post. See "Section Thru Rail Element".
- Slotted holes for splice bolts to overlap ends of rail element. See "Section Thru Rail Element".
- Install posts in soil.

STATE OF CALIFORNIA  
DEPARTMENT OF TRANSPORTATION

**METAL BEAM GUARD RAILING  
STANDARD RAILING SECTION  
(STEEL POST WITH NOTCHED  
WOOD OR NOTCHED  
RECYCLED PLASTIC BLOCK)**

NO SCALE

**A77A2**