

PLAN  
TYPE G1

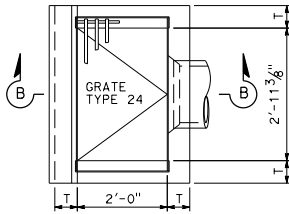

PLAN  
TYPE G3

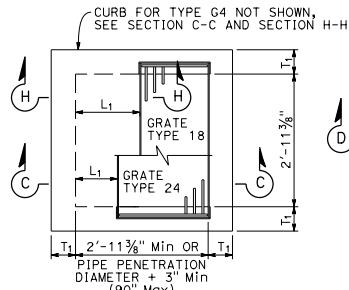

PLAN  
STANDARD  
TYPE G2 OR G4

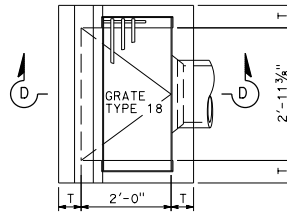

PLAN  
TYPE G5

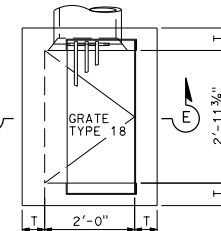

PLAN  
TYPE G6

DIST	COUNTY	ROUTE	POST MILES TOTAL PROJECT	SHEET NO.	TOTAL SHEETS
------	--------	-------	--------------------------	-----------	--------------

July 15, 2016  
 PLANS APPROVAL DATE  
 THE STATE OF CALIFORNIA OR ITS OFFICERS OR AGENTS SHALL NOT BE RESPONSIBLE FOR THE ACCURACY OR COMPLETENESS OF SCANNED COPIES OF THIS PLAN SHEET.

TO ACCOMPANY PLANS DATED \_\_\_\_\_

**NOTE:**  
1. For notes and Table 2, See Revised Standard Plan RSP D72C.

	T <sub>1</sub>	Vert BARS
L <sub>1</sub> AND L <sub>2</sub> < 2'-10"	9"	#4 @ 12
L <sub>1</sub> OR L <sub>2</sub> > 2'-10"	12"	#5 @ 12

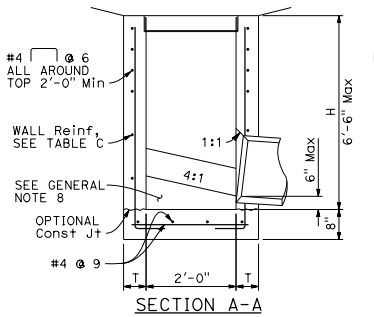

SECTION A-A

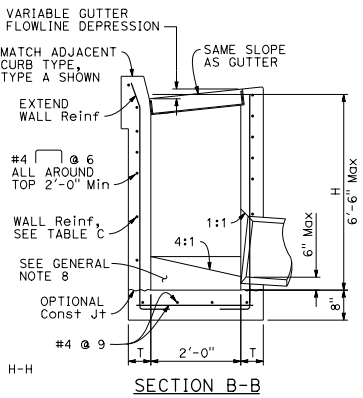

SECTION B-B

FOR "L<sub>1</sub>", "L<sub>2</sub>" AND "T<sub>1</sub>" VALUES, SEE "TABLE 1"

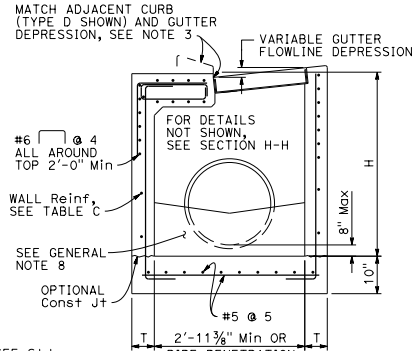

SECTION C-C

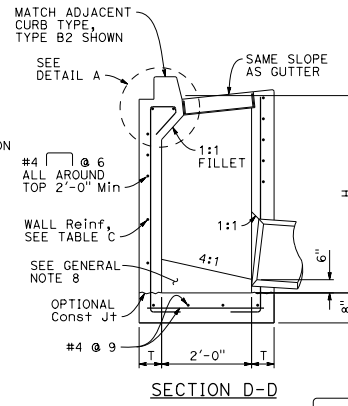

SECTION D-D

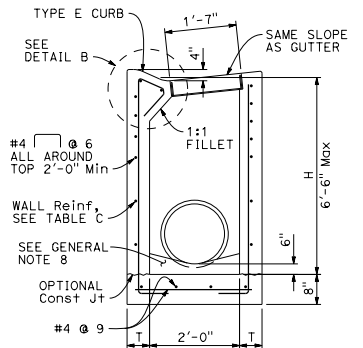

SECTION E-E

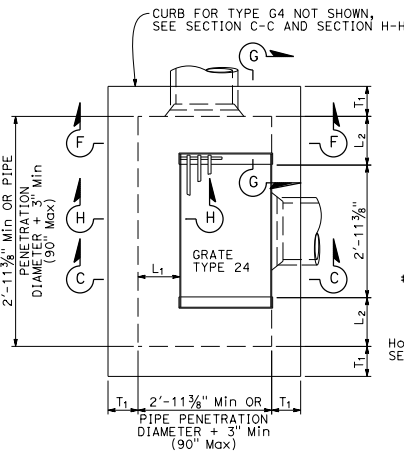

PLAN  
EXPANDED  
TYPE G2 OR G4

(INTEGRAL TOP ALTERNATIVE)  
FOR "L<sub>1</sub>" AND "T<sub>1</sub>" VALUES, SEE TABLE 1

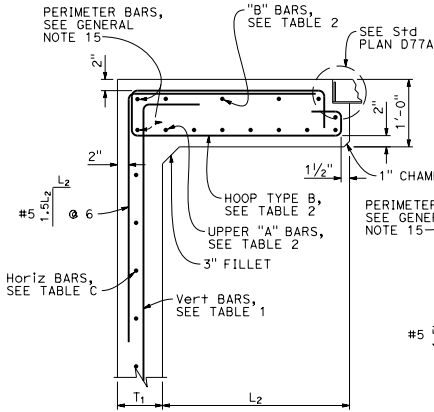

SECTION G-G

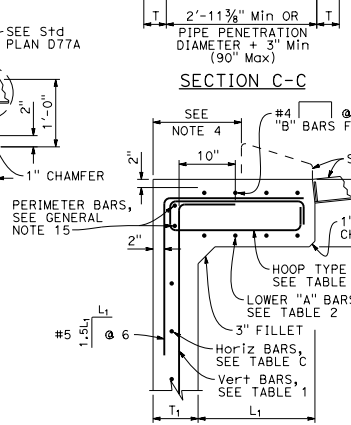

SECTION H-H

FOR "L<sub>1</sub>", "L<sub>2</sub>" AND "T<sub>1</sub>" VALUES, SEE "TABLE 1"

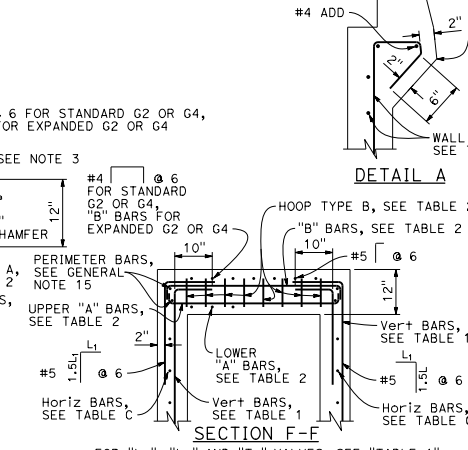

SECTION F-F

FOR "L<sub>1</sub>", "L<sub>2</sub>" AND "T<sub>1</sub>" VALUES, SEE "TABLE 1"

DETAIL A

DETAIL B

STATE OF CALIFORNIA  
DEPARTMENT OF TRANSPORTATION  
**CIP DRAINAGE INLETS  
TYPES G1, G2, G3,  
G4, G5 AND G6**  
NO SCALE

REVISED STANDARD PLAN RSP D72B

2015 REVISED STANDARD PLAN RSP D72B