

GENERAL NOTES:

- "H" is measured from top of bottom slab to the normal gutter grade line undepressed at the curb face.
- For "T" wall thickness and reinforcement, see Table C on Revised Standard Plan RSP D73G.
- Wall reinforcement must be placed at the center of wall thickness with horizontal bars placed on the exterior face. Bottom slab concrete cover must be 3" clear on the interior side face unless otherwise noted. Top slab concrete cover must be 2" clear on the exterior face unless otherwise noted. Short independent wall sections or height adjustment rings 6" to 24" high must have a minimum of two #4 horizontal bars. Reinforcement spacing is in inches unless otherwise noted.
- Steps - None required where "H" is less than 2'-6". Where "H" is 2'-6" or more, install steps with lowest rung 1'-0" above the floor and highest rung not more than 6" below bottom of lid. The distance between steps must not exceed 1'-0" and be uniform throughout the length of the wall. Place steps in the wall without an opening. Steps inserts may be substituted for the bar steps. Step Inserts must comply with State Industrial Safety Requirements. See Revised Standard Plan RSP D74 for step details.
- Pipe(s) can be placed in any wall. Adjacent to each side of the opening, place additional reinforcement equivalent to half the interrupted main reinforcement. For larger pipes greater than or equal to 42" diameter, also add 4 diagonal bars, 1 bar each side. Bars must be the same size as the larger of the main vertical or horizontal bars. Extend bars one development length past the intersection with the adjacent diagonal bar, or where bars intersect mid thickness of adjacent wall bottom or top of non-continuous wall, bend ends as required into same plane.
- Set inlet so that grate bars are parallel to direction of principal surface flow.
- Curb section must match adjacent curb.
- Except for inlets used as junction boxes, basin floors must have wood trowel finish and a minimum slope of 4:1, unless otherwise noted, from all directions toward outlet pipe by casting grout on top of the bottom slab. Grout must be placed prior to backfill.
- See Standard Plans D77A and D77B for grate and frame details and weights of miscellaneous iron and steel.
- See Standard Plans D78A and D78B for gutter depression details.
- See Standard Plan A87A and Revised Standard Plan RSP A87B for curb and dike details.
- Details shown apply to metal, concrete and plastic pipe(s).
- The Contractor may use WWR instead of bar reinforcement. The ratio of bar reinforcement to WWR shall be based on the yield strength ratio.
- Seal precast inlets connection openings between wall and pipe with non-shrink grout or resilient connectors as specified in the Special Provisions. Precast inlets shall have mortared connections conforming to details for Type GCP Inlet shown on Standard Plan D75B. See Standard Specifications for mortar composition.
- Where shown, provide precast inlets with separate top sections for final grade adjustment. Provide keyed joints with butyl rubber sealant between the top section and wall, multiple wall sections, and wall and bottom slab. Joint design may vary but must be 1" to 3" in depth. For tongue type joints, tongue down orientation is not allowed. For keyed joints, keyway up, keyway down or tongue up configurations are allowed. Only one key type is allowed for each drainage inlet.
- Non-shrink grout can be used for upper most joint to facilitate final top grade adjustment.
- Provide a level and firm sand bedding on which to place precast inlets. Extend sand bedding under all structure backfill.
- For Integral Base, see Detail "A".
- Perimeter reinforcement must not be smaller than main bars and #4 and serves as a rigid frame to position and attach the required structural reinforcement and may be tack welded at outer corners when using ASTM A706 weldable bars.
- Inlet extensions may be cast in place after placement of main box and placement and compaction of backfill. Concrete strength must be 3.6 ksi minimum. All slab and wall thicknesses must be per Revised Standard Plan RSP D72A. All reinforcement shall extend a minimum of 24" from precast main inlet box.

DESIGN NOTES:

- Design Specifications: AASHTO LRFD Bridge Design Specifications, 6th edition with 2012 Interims and Errata and CA Amendments.
- Live Load (AASHTO LRFD 3.6.1.2): HL-93, consists of design truck or tandem, and design lane load. Dynamic Load Allowance, IM = 33%. Multiple Presence Factor, m = 1.0. Design lane load was excluded in Top Slab design. A wheel load of 8 kips without impact factor was used for top slabs that are above a curb.
- Earth Load:
Vertical pressure = 140 pcf
Lateral pressure:
= 100 pcf for walls with flat embankment
= 140 pcf For walls with slope embankment, 1.5:1 Max
- Downdrag: $\phi = 34^\circ$ and $\gamma_c = 120$ pcf.
- Buoyancy: $\gamma_w = 62.4$ pcf to finished grade.
- Reinforced Concrete: $f'_c = 5.0$ ksi, $f_y = 60.0$ ksi.
- Tables are based on the worst case from the level ground and sloped ground.
- Soil pressures shown are factored per AASHTO LRFD and include self-weight, live load and downdrag.

SPAN "A" OR "B" (IN)	L (IN)
<38	34
38 TO 50	40
51 TO 64	47
65 TO 76	53
77 TO 90	60

DIST	COUNTY	ROUTE	POST MILES TOTAL PROJECT	SHEET NO.	TOTAL SHEETS



 REGISTERED CIVIL ENGINEER
 July 15, 2016
 PLANS APPROVAL DATE
 THE STATE OF CALIFORNIA OR ITS OFFICERS OR AGENTS SHALL NOT BE RESPONSIBLE FOR THE ACCURACY OR COMPLETENESS OF SCANNED COPIES OF THIS PLAN SHEET.

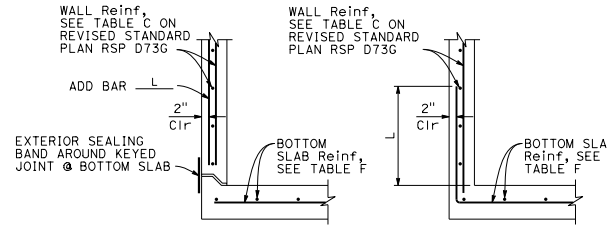

BASE WITH KEYED JOINT INTEGRAL BASE

DETAIL "A"

FOR INTEGRAL BASE, CLEARANCE BETWEEN PIPE PENETRATION AND BASE SLAB MAY BE AS SHOWN IN CIP ALTERNATIVE STANDARD PLAN SHEET.

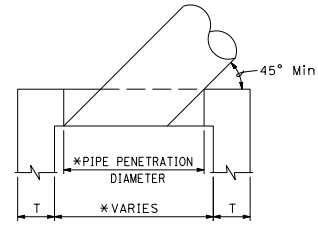

SKWEVED PIPE PLAN

* ADJUST PIPE PENETRATION AND BOX WIDTH FOR SKWEVED PIPES.

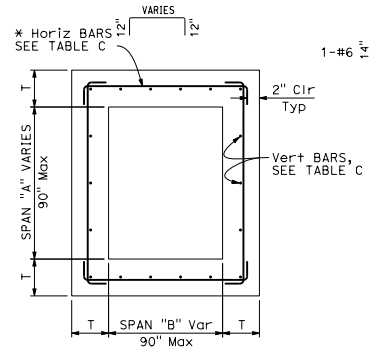

TYPICAL INLET PLAN

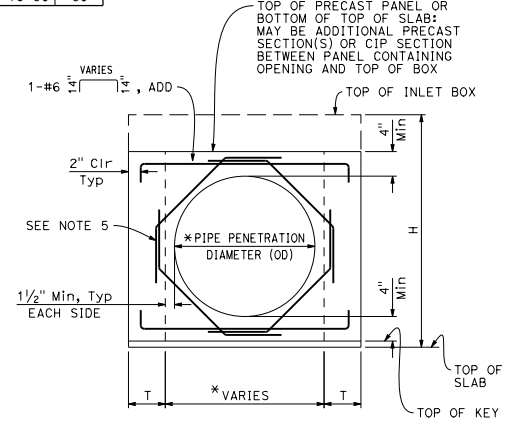

BASE WITH KEYED JOINT

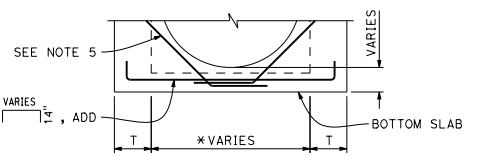

INTEGRAL BASE

FOR DETAILS NOT SHOWN, SEE "BASE WITH KEYED JOINT"

TYPICAL WALL W/ PIPE OPENING

* SEE "SKEWED PIPE PLAN"

STATE OF CALIFORNIA
DEPARTMENT OF TRANSPORTATION

PRECAST DRAINAGE INLET NOTES
NO SCALE

RSP D73F DATED JULY 15, 2016 SUPPLEMENTS THE STANDARD PLANS BOOK DATED 2015.

REVISED STANDARD PLAN RSP D73F

2015 REVISED STANDARD PLAN RSP D73F