

DIST	COUNTY	ROUTE	POST MILES TOTAL PROJECT	SHEET TOTAL SHEETS

REGISTERED CIVIL ENGINEER  
 May 31, 2018  
 PLANS APPROVAL DATE  
 THE STATE OF CALIFORNIA OR ITS OFFICERS OR AGENTS SHALL NOT BE RESPONSIBLE FOR THE ACCURACY OR COMPLETENESS OF SCANNED COPIES OF THIS PLAN SHEET.

2018 STANDARD PLAN B11-57

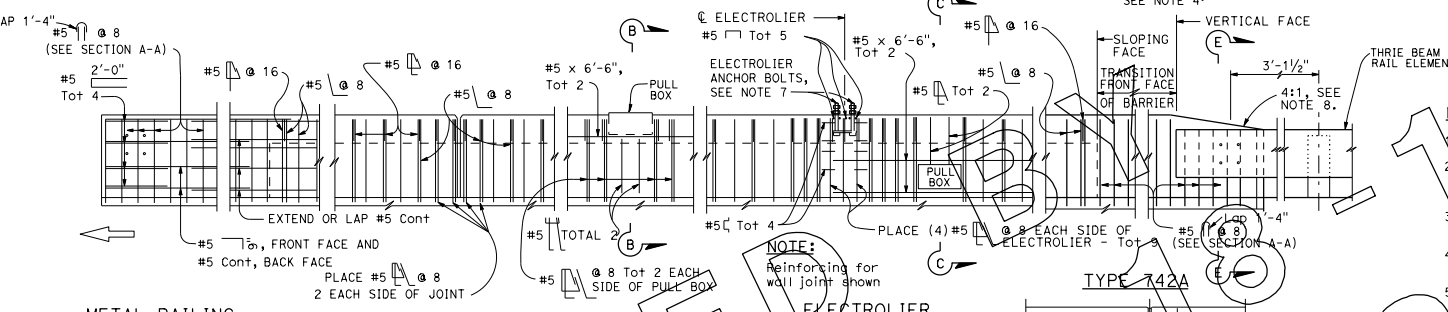
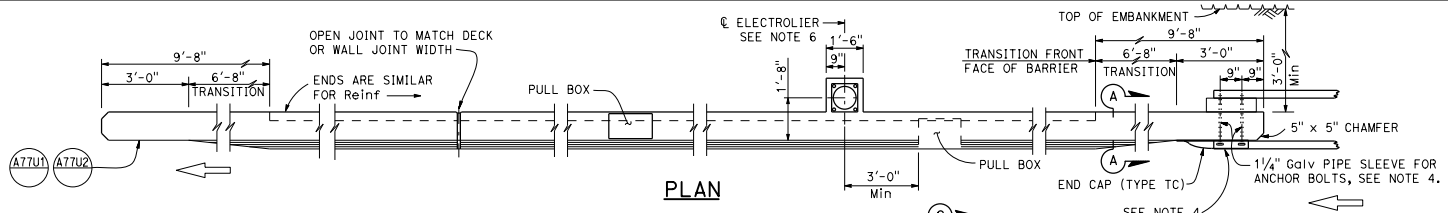

- NOTES:**
1. Walls are to be backfilled before barrier is placed.
  2. Clearance to reinforcing steel in barrier to be 1", except as noted. Longitudinal reinforcement to stop at all expansion joints.
  3. Dimensions may vary with roadway cross slope and with certain thickness of supporting. See Project Plans.
  4. For typical metal railing connection details not shown, see Standard Plans 477U1 and 477U2.
  5. See Standard Plans ES-9A, ES-9B, ES-9C, ES-9D and ES-9E for electrical details. The maximum number of conduits in the barrier is limited to two 2" conduits along with one 3" conduit. When a 3" conduit is used, it is restricted to the base of the barrier.
  6. For electrolier mounting details, see Standard Plans ES-6A and ES-6B.
  7. Minimum concrete edge distance, to the reinforcing shown, shall be maintained. Edge distance may be adjusted to accommodate increase in concrete cover for architectural treatment.
  8. Taper the top of the end of the bridge railing at 4:1 to match the top elevation of the three beam rail element.

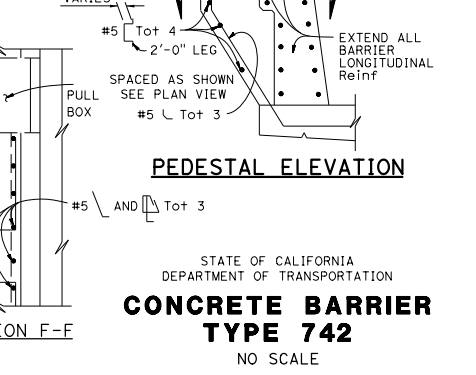
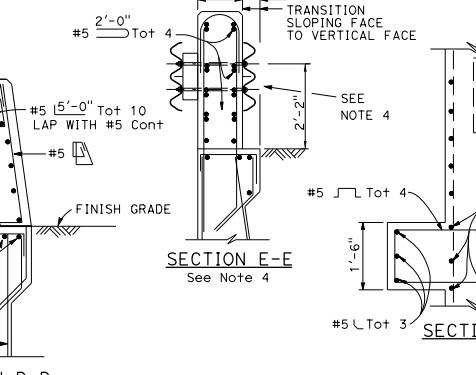
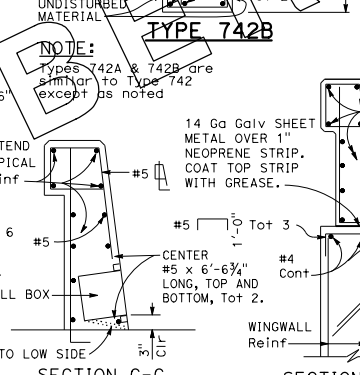
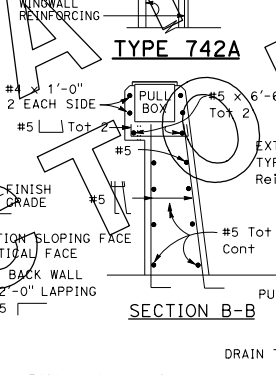
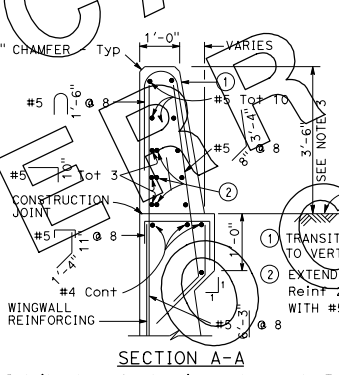
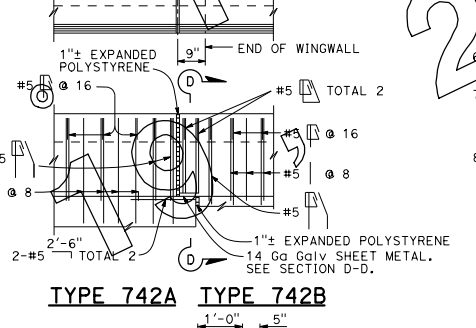
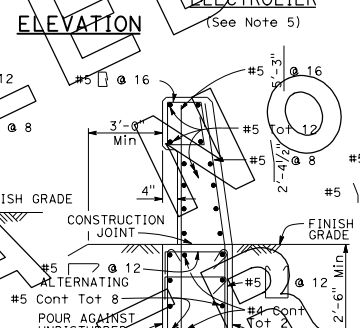
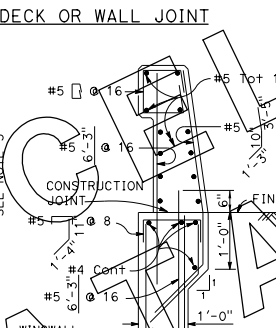
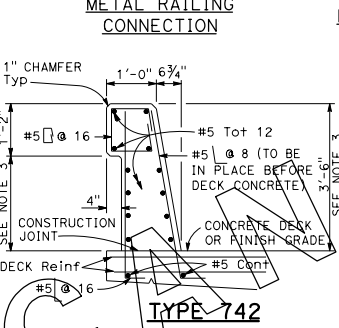

Details shown for barrier anchorage to Type 742A. Anchorage for barrier Types 742 and 742A are similar to their respective details.

STATE OF CALIFORNIA  
 DEPARTMENT OF TRANSPORTATION  
**CONCRETE BARRIER  
 TYPE 742**  
 NO SCALE

**B11-57**

364