

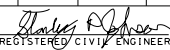

Dist	COUNTY	ROUTE	POST MILES TOTAL PROJECT	SHEET No.	TOTAL SHEETS

 REGISTERED CIVIL ENGINEER
 No. CS1793
 Exp. 3-31-20
 CIVIL
 STATE OF CALIFORNIA

October 19, 2018
 PLANS APPROVAL DATE
 THE STATE OF CALIFORNIA OR ITS OFFICERS OR AGENTS SHALL NOT BE RESPONSIBLE FOR THE ACCURACY OR COMPLETENESS OF SCANNED COPIES OF THIS PLAN SHEET.

LEGEND

-  Wood Pole with Attachments
- TS- Overhead Bundle with Signal Faces (See Note 2)
- OH- Overhead Bundle
-  Guy Anchor

POLE SELECTION TABLE

OVERHEAD BUNDLE HORIZONTAL SPAN Max	MAXIMUM dp	CASE 1GT			CASE 2GT			CASE 3GT		
		1"	1.5"	2.0"	1"	1.5"	2.0"	1"	1.5"	2.0"
50'	MINIMUM POLE CLASS	H-2	H-3	H-3	H-2	H-2	H-2	H-3	H-4	H-4
	POLE EMBEDMENT (E)	10'			10'			11'		
100'	MINIMUM POLE CLASS	H-3	H-3	H-4	H-2	H-3	H-3	H-4	H-4	H-5
	POLE EMBEDMENT (E)	11'			10'			11'		
150'	MINIMUM POLE CLASS	H-3	H-4	H-4	H-2	H-3	H-4	H-4	H-5	H-5
	POLE EMBEDMENT (E)	11'			10'			11'		

NOTES:

- In addition to other restrictions on maximum horizontal span, this horizontal span must not exceed 100'.
- Maximum of 2 SIGNAL FACES per span within the hatched regions indicated by "LOCATION OF SIGNAL FACES".
- Guy wire in line with opposing span $\pm 5^\circ$.

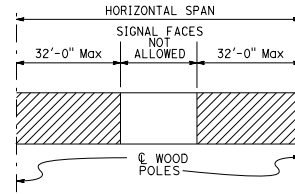

LOCATION OF SIGNAL FACES

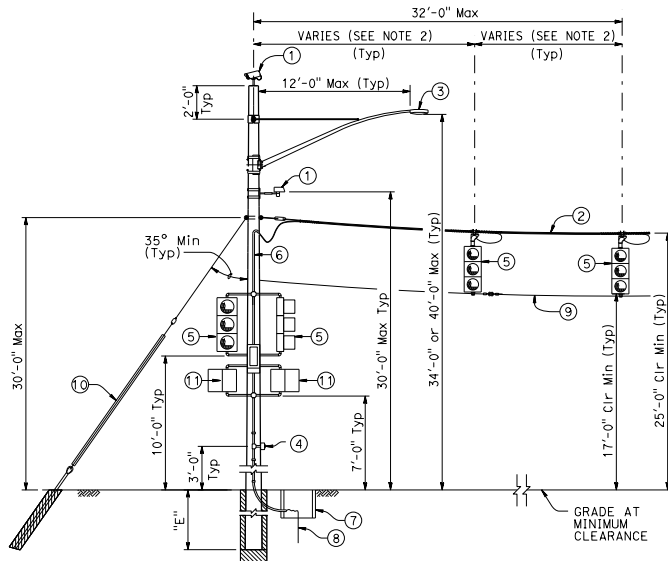

**CASE 1GT
POLE AT DEAD END
WITH ATTACHMENTS**

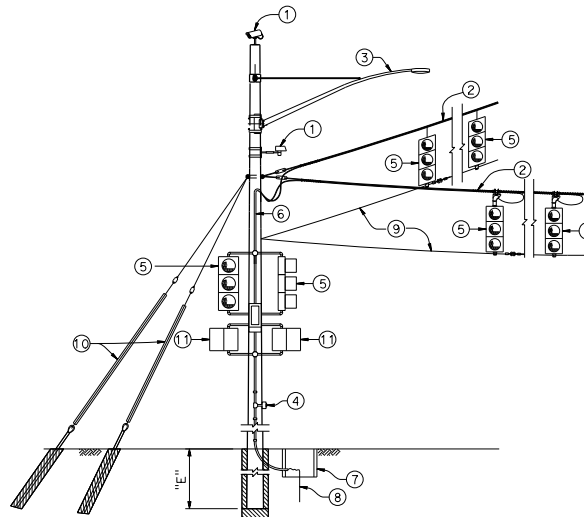

**CASE 2GT
POLE AT CORNER
WITH ATTACHMENTS**

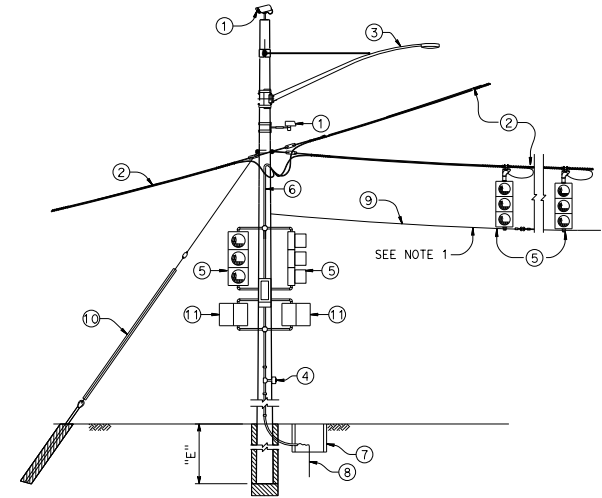

**CASE 3GT
POLE AT JUNCTION WITH ATTACHMENTS**

STATE OF CALIFORNIA
DEPARTMENT OF TRANSPORTATION
**TEMPORARY WOOD POLES
GUYED - WITH SIGNAL FACES ON SPANS**
NO SCALE

RSP ES-180 DATED OCTOBER 19, 2018 SUPERSEDES STANDARD PLAN ES-180
DATED MAY 31, 2018 - PAGE 560 OF THE STANDARD PLANS BOOK DATED 2018.

REVISED STANDARD PLAN RSP ES-180

2018 REVISED STANDARD PLAN RSP ES-180