

Gutter not shown

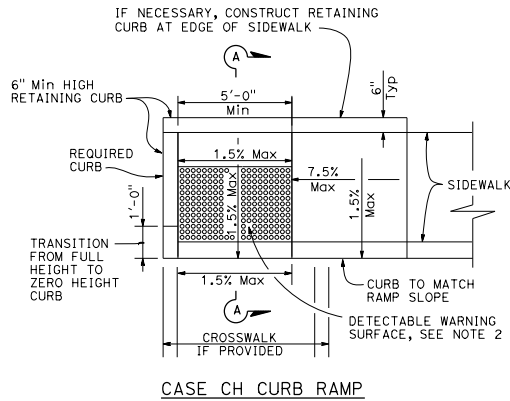
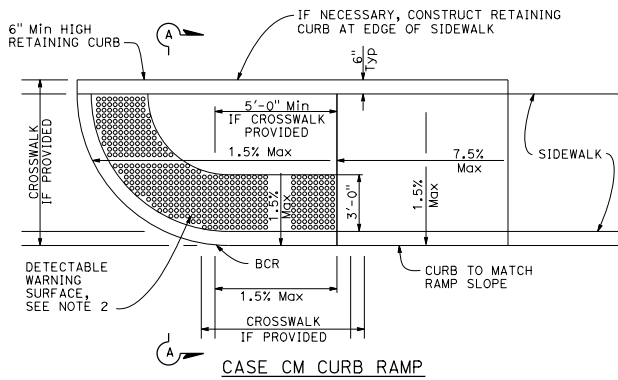

**NOTES:**

1. Sidewalk, ramp and passageway thickness, "T", shall be 3/2" minimum.
2. For details of detectable warning surfaces, see Revised Standard Plan RSP A88A.
3. Where an island passageway length is greater than or equal to 8'-0", but less than 8'-0", each detectable warning surface shall extend the full width and 2'-0" depth of the passageway length. Where an island passageway length is greater than or equal to 8'-0", each detectable warning surface shall extend the full width and 3'-0" depth of the passageway length. Detectable warning surfaces shall extend the full width of the island passageway except a maximum gap of 1 inch is allowed on each side of the passageway.
4. The adjacent surfaces at transitions at curb ramps to walks, gutters, and streets shall be at the same level.
5. Utility pull boxes, manholes, vaults and all other utility facilities within the boundaries of the curb ramp will be relocated or adjusted to grade by the owner prior to, or in conjunction with, curb ramp construction.
6. Detectable warning surface may have to be cut to allow removal of utility covers while maintaining detectable warning width and depth.
7. For additional curb ramp details, see Revised Standard Plan RSP A88A.
8. The detectable warning surface will be a rectangle as shown at the face of curb, unless modified in the Project Plans.

DIST	COUNTY	ROUTE	POST MILES TOTAL PROJECT	SHEET NO.	TOTAL SHEETS

PLANS APPROVAL DATE: July 21, 2017

REGISTERED CIVIL ENGINEER: Hector David Cordova  
No. C41957  
Exp. 3-31-18  
CIVIL

STATE OF CALIFORNIA PROFESSIONAL ENGINEER

TO ACCOMPANY PLANS DATED \_\_\_\_\_

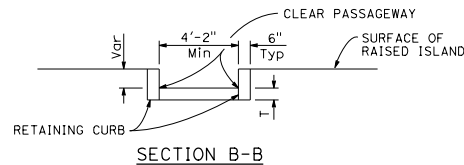
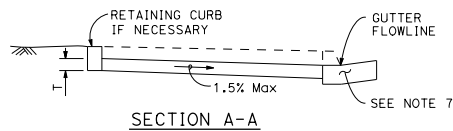
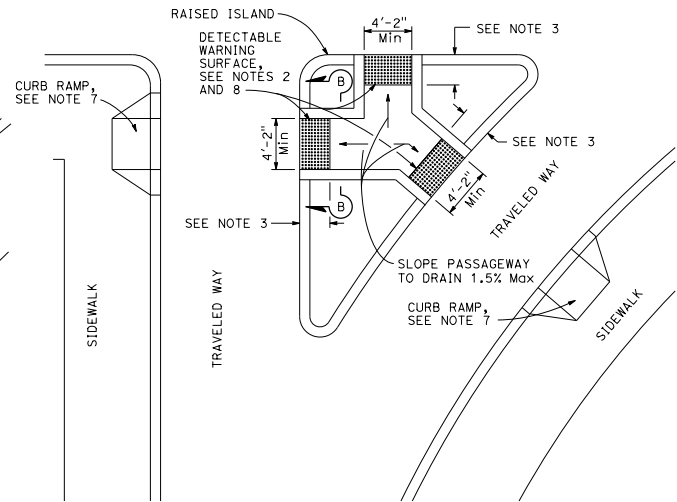
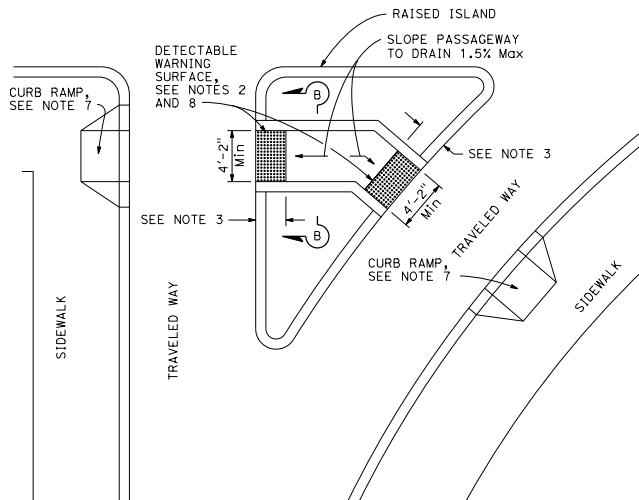
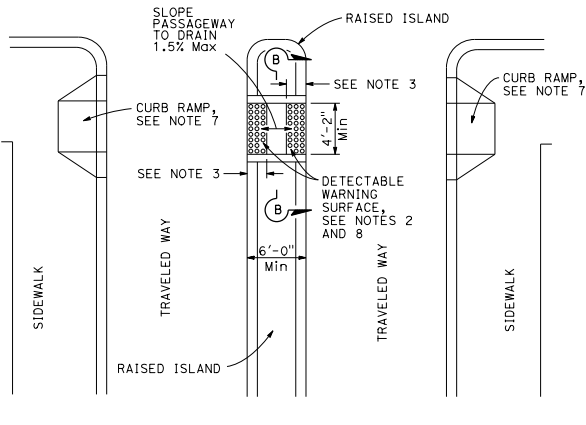

STATE OF CALIFORNIA  
DEPARTMENT OF TRANSPORTATION  
**CURB RAMP AND ISLAND PASSAGWAY DETAILS**  
NO SCALE

RSP A88B DATED JULY 21, 2017 SUPERSEDES RSP A88B DATED JULY 15, 2016 AND STANDARD PLAN A88B DATED OCTOBER 30, 2015 - PAGE 128 OF THE STANDARD PLANS BOOK DATED 2015.  
**REVISED STANDARD PLAN RSP A88B**

2015 REVISED STANDARD PLAN RSP A88B