

* 1' Min WHERE LATERAL CLEARANCE LIMITED

URBAN LOCATIONS

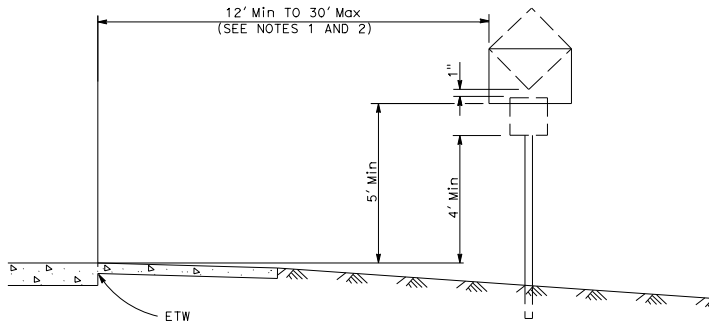

RURAL LOCATIONS

CONVENTIONAL HIGHWAYS AND INTERCHANGE AREAS

DIST	COUNTY	ROUTE	POST MILES TOTAL PROJECT	SHEET NO.	TOTAL SHEETS

Donald E. Howe
 REGISTERED CIVIL ENGINEER
 May 31, 2018
 PLANS APPROVAL DATE
 No. C46402
 Exp. 3-31-19
 CIVIL
 STATE OF CALIFORNIA
 REGISTERED PROFESSIONAL ENGINEER

THE STATE OF CALIFORNIA OR ITS OFFICERS OR AGENTS SHALL NOT BE RESPONSIBLE FOR THE ACCURACY OR COMPLETENESS OF SCANNED COPIES OF THIS PLAN SHEET.

NOTES:

1. When clear roadside recovery areas are provided, signs shall be placed as far from the edge of traveled way as possible, up to a maximum of 30'. When possible, they shall be placed in protected locations.
2. Signs in medians shall be placed at midpoint of median up to a maximum distance of 30' from edge of traveled way. When appropriate, signs for opposing directions shall be placed back to back.
3. Does not apply at locations where minimum horizontal distance is not reasonable due to terrain characteristics, steep slopes, roadway features, or when signs are installed on structures or signal or lighting standards.

ABBREVIATION:

EPS = Edge of Paved Shoulder

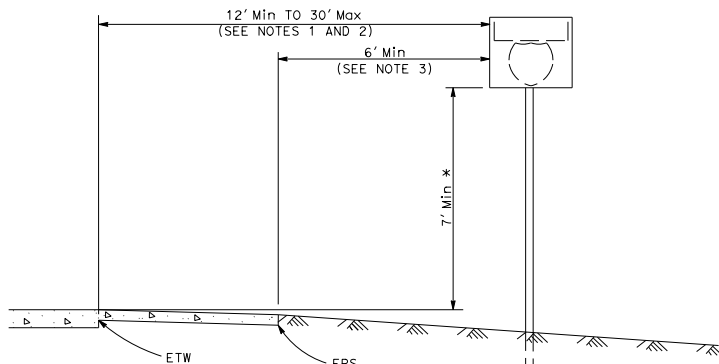

* 5' Min AT 30' FROM ETW

REGULATORY AND WARNING SIGNS AND ROUTE SHIELDS

FREEWAY AND EXPRESSWAY LOCATIONS

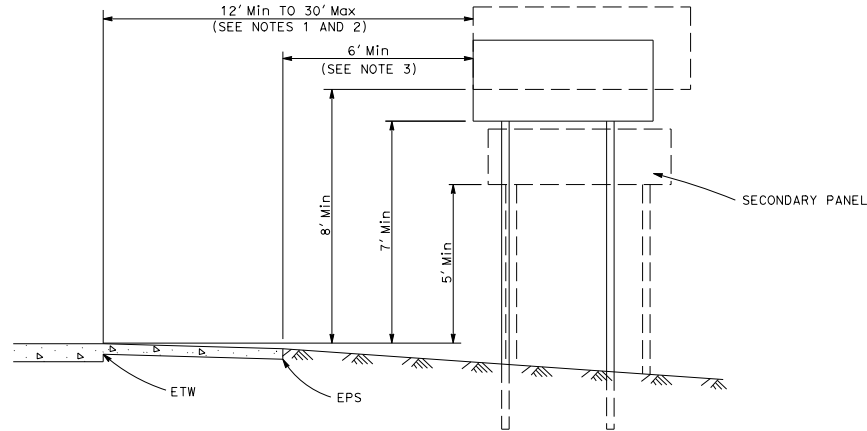

GUIDE SIGNS

STATE OF CALIFORNIA
 DEPARTMENT OF TRANSPORTATION
**ROADSIDE SIGNS
 TYPICAL INSTALLATION
 DETAILS No. 1**

NO SCALE